

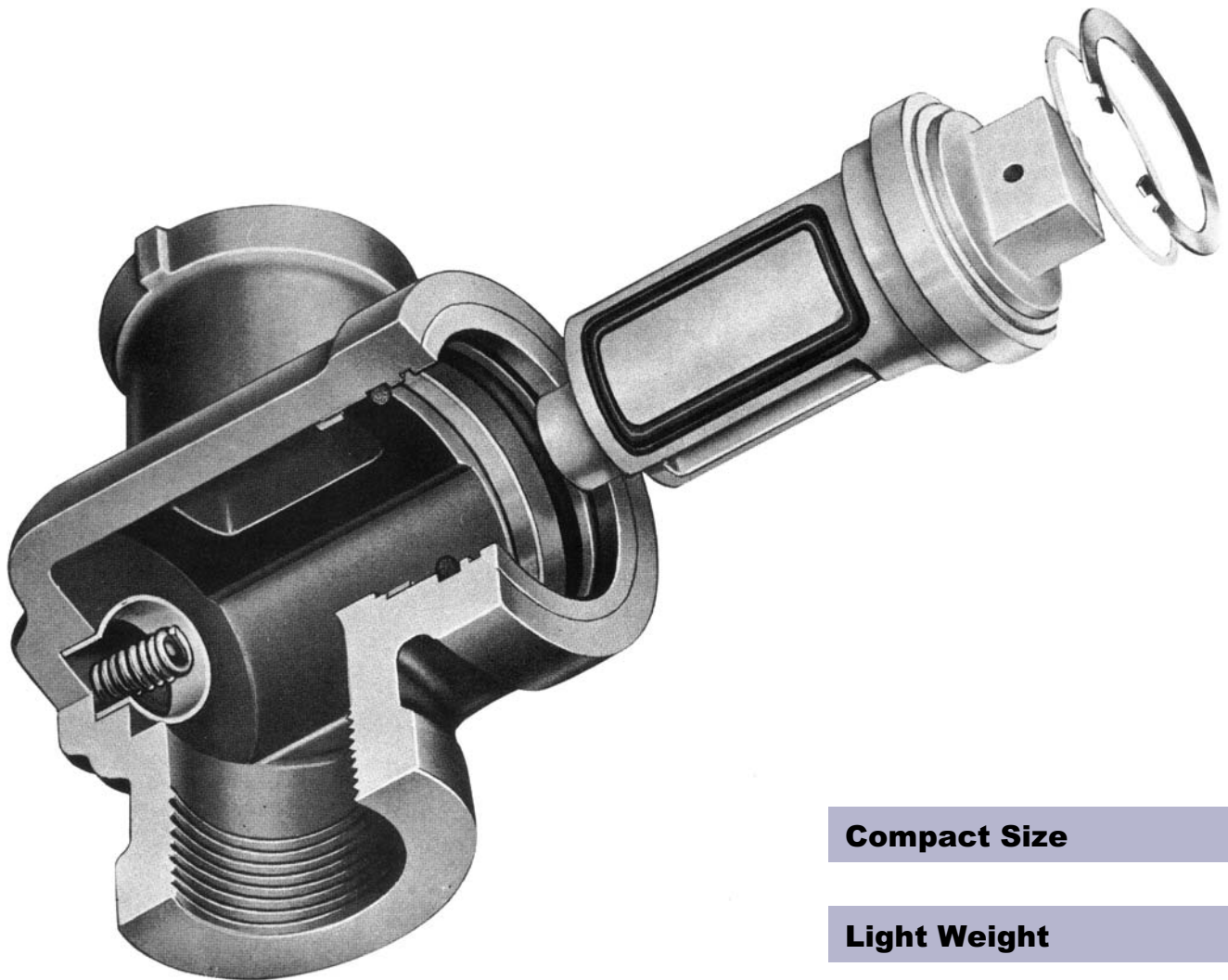

KEY PORT®

SERIES 400 ECCENTRIC VALVES



Compact Size

Light Weight

UL Listed

CSA Certified



Bulletin
11.00-1
September, 2006

Design & Construction

KEY PORT® Series 400 Eccentric Valves combine proven design and quality construction to provide dependable long life for a variety of applications.

1 Corrosion resistant plug

Plug materials resist corrosion and prolong seat life. Available materials are as follows:
Bronze (½" - 2" only)
Electroless nickel plated cast iron (2½" - 4" valves only).

2 Double-seal for tight shutoff and safety.

A resilient seal molded into a groove in the plug face assures dead-tight shutoff on liquids and gases without the use of sealing lubricants. When the plug is closed, the resilient seal is compressed against the seat. The metal on the plug face also makes contact with the metal seat to provide a second seal for safety. Gas industry fire tests showed that this second metal seal provides nearly bubble-tight shutoff with the resilient seal burned away.

3 O-Ring stem seal

A variety of stem seal materials provides maintenance-free sealing that matches valve performance and assures long life and reliability.

4 Corrosion resistant bearings

Permanently lubricated bearings in the upper and lower plug journals resist corrosion and assure easy operation without lubrication. And, operation is just as easy whether the valve is operated once a day or once a year.

5 Corrosion resistant seal

A baked on thermoplastic seat coating provides extra corrosion resistance to minimize plug wear.

6 Meets ANSI 125 lb. standard

Body walls and end connections conform to all applicable ANSI 125 pound standards. Valves meet MSS standards in ½" and ¾" sizes where ANSI standards are not available.

7 Choice of end connections

A complete choice of end connections includes screwed, flanged, Dresser and Victaulic. A complete listing of availability for each valve size and FIG number is shown in the ordering section.

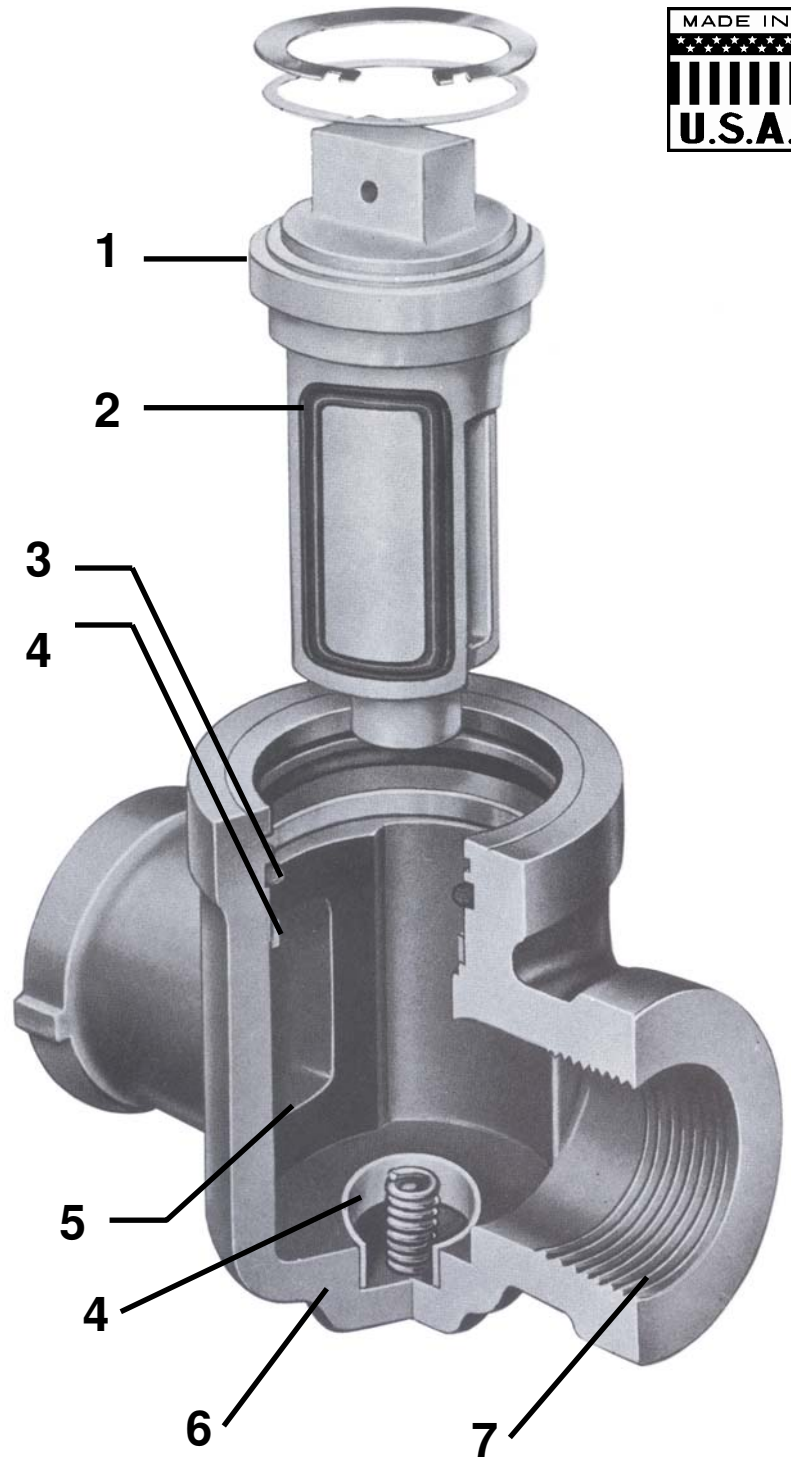

Rev. 1, July, 1973
Rev. 2, January, 1977
Rev. 3, February, 1979
Rev. 4, August, 1980
Rev. 5, January, 1988
Rev. 6, July, 2001
Rev. 7, September, 2006

Actuators & Accessories

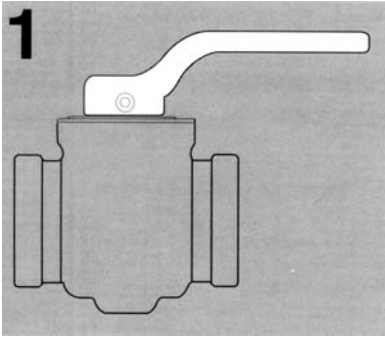
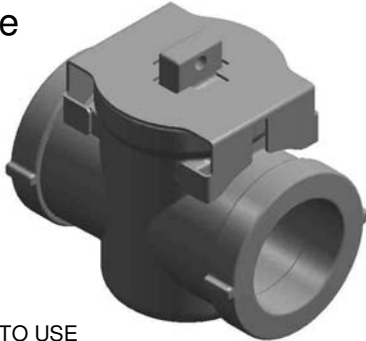

FIG 483 lever - Order as a separate item by giving "FIG 483" followed by valve size code (0100 = 1", 0200 = 2", etc.). Note: FIG 487 Memory Stop cannot be used with the FIG 483 lever.

ORDERING EXAMPLE: FIG 483, 0200.

Series 400 Eccentric Lock On-Off Device



- EASY TO USE
- INSTALLS QUICKLY AND EASILY
- MADE OF 304 STAINLESS STEEL
- MODELS TO FIT 400 SERIES VALVES FROM 1/2" TO 4"
- WILL FIT THREADED OR FLANGED VALVES

Series 400 Eccentric Lock Out Device

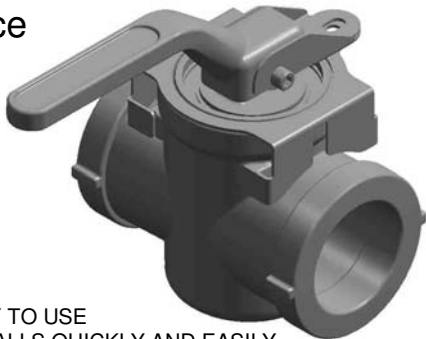

- EASY TO USE
- INSTALLS QUICKLY AND EASILY
- MADE OF 304 STAINLESS STEEL
- MODELS TO FIT 400 SERIES VALVES FROM 1/2" TO 4"
- WILL FIT THREADED OR FLANGED VALVES
- CAN BE USED WITH UL LISTED VALVES
- (VALVE CAN ONLY BE LOCKED IN THE CLOSED POSITION)

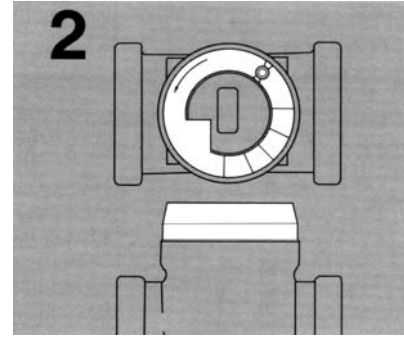

FIG 487 adjustable memory stop and plastic drip cap -- if ordered with valve, add "FIG 487" to valve description.

ORDERING EXAMPLE: 0200, FIG 425, S, 3, RS55, FIG 487.

If ordering separately, give "FIG 487" followed by valve size code (0100 = 1", 0200 = 2", etc.)

ORDERING EXAMPLE: FIG 487, 0200.

1/8" Gage tap - In upstream or seat end of valve. To order, add description and tap location to valve identification.

ORDERING EXAMPLE: 0200, FIG 425, S, 3, RS55, with 1/8" tap on seat end of valve.

FIG 630 dresser and accessories --

Order as a separate item by giving "FIG 630" followed by valve size code (0100 = 1", 0200 = 2", etc.) and Dresser End Code shown below.

Accessories for 3/4" - 2" are Dresser Style 90 with bonderized follower nuts. Accessories for 2 1/2" - 4" are Dresser Style 38 with bolted couplings.

- 1 Standard.** With armored grade 27 gaskets. Brass coil in the gasket protects rubber and makes a positive electrical contact between valve and pipe.
- 2 Locking.** With steel balls in gaskets to prevent pipe from pulling out of valve.
- 3 Insulating.** Prevents electric current flow along pipe. Valves with Dresser Insulating ends have the end opposite the seat only machined for Dresser Insulating accessories. The seat end is machined for Dresser Standard accessories.

ORDERING EXAMPLE: FIG 630, 0200, 1.

Valve Sizing & Rating

Sizes 1/2" - 4" — KEY PORT Series 400 Eccentric Valves are available in 9 sizes from 1/2" - 4". This valve is ideal for many applications including HVAC systems, natural gas and combined hot and chilled water service.

Compact Size, Light in Weight — Small body size makes this valve ideal for applications where space is limited. See dimensions. Light weight minimizes the need for pipe supports. Weights are shown in the dimension table.

High Flow Capacity — Large port areas and straight through flow provide high flow capacity. Cv values are shown below. Figures are based on discharge into conduit rather than atmosphere and are an average between valves with screwed and flanged ends. Cv's are slightly higher for flanged valves and slightly lower for screwed valves.

VALVE SIZE	Cv VALUES—WIDE OPEN (Flow in GPM of Water at 1 psi pressure drop)
1/2"	9
3/4"	22
1"	35
1 1/4"	54
1 1/2"	78
2"	135
2 1/2"	180
3"	270
4"	500

Single Valve Balancing and Shutoff for Air Conditioning Application

The optional FIG 487 Adjustable Memory Stop provides both balancing and shutoff in one valve. With the memory stop locked in place, except when equipped with an attached lever actuator, the valve can be closed and then reopened to the same balanced position. Included with the memory stop, shown on page 4, is a drip cap to reduce dripping from sweating valves on chilled water applications.

Ideal for Combined Hot and Chilled Water Service — KEY PORT High Temp (Isobutene-Isoprene) plug seals make the Series 400 Eccentric ideal for combined hot and chilled water heating and cooling systems. This compound is suitable for water service at temperatures up to 250 degrees F.

U.L. Listed — KEY PORT FIG 425 valves with RS 49 and RS 51 plug seals are listed by Underwriters Laboratories, Inc., for a variety of applications including: manual burner shutoff of city gas supplied by public utilities; fuel oils; compressed gas line shutoff; and miscellaneous valves for general use in air and water piping for fire protection equipment. Write SMG VALVES for a copy of the complete U.L. listing.

CSA Certified -- KEY PORT FIG 425 valves are CSA certified, for a variety of applications.

Pressure Ratings — KEY PORT Series 400 Eccentric Valves with standard cast iron bodies have a W.O.G. non-shock working pressure of 175 psi.

Series 400 Eccentric Valves provide dead-tight shutoff on liquids or gasses at pressure differentials up to the maximums shown below:

VALVE SIZE	Maximum Shutoff Differential		
	Actuator	Forward*	Reverse**
1/2" - 4"	All Actuators	175 psi	75 psi

* Pressure against the back of the plug tending to push the plug into the seat.

** Pressure against the face of the plug tending to push the plug away from the seat.



Open

KEY PORT Valve® eccentric action and resilient seating assure lasting dead-tight shutoff. As the eccentric plug rotates 90 degrees from open to closed, it moves into a raised eccentric seat.

In the open position, flow is straight through and flow capacity is high.

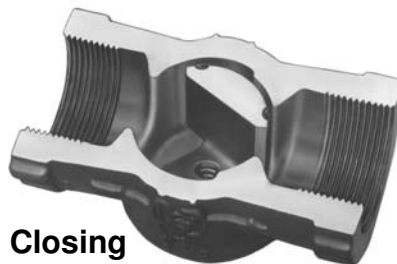

Closing

As the plug closes, it moves toward the seat without scraping the seat or body walls so there is no plug binding or wear. Flow is still straight through making the throttling characteristic of this valve ideal for manual throttling of gasses and liquids.

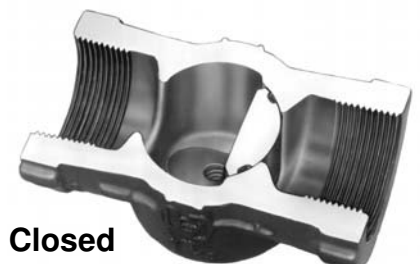

Closed

In the closed position, the plug makes contact with the seat. The resilient plug seal is pressed firmly into the seat for dead-tight shutoff. Eccentric plug and seat design assure lasting shutoff because the plug continues to move into the seat until firm contact and seal is made.

Materials & Ordering

To Order, give the complete valve identification by specifying the ordering code for each item as shown below. An ordering example is shown at the bottom of the page.

**ORDERING EXAMPLE: To Order a 2" screwed body Fig 425 for high temperature equipped w/ memory stop, the order would be as follows:
0200, FIG 425, S, 3, RS55, FIG 487**

Valve Size

Give Size Code as Follows:

0050	=	1/2"
0075	=	3/4"
0100	=	1"
0125	=	1 1/4"
0150	=	1 1/2"
0200	=	2"
0250	=	2 1/2"
0300	=	3"
0400	=	4"

0200,

Figure Number (Material)

Give "FIG" and number that follows:

FIG 425	=	Cast Iron Body Bronze Plug (1/2"-2") Electroless Nickel Plated Cast Iron Plug (2 1/2"-4") Bronze Bearings
FIG 499	=	Air Conditioning Balancing Valve Bronze Plug (1/2"-2") Electroless Nickel Plated Cast Iron Plug (2 1/2"-4") Bronze Bearings Same as FIG 425 except with FIG 487 stop ring, drip cap and 1/8" tap on seat end of valve

FIG 425,

End Style

Give end style code as shown below. Description give availability by FIG number and size.

S	=	SCREWED — Both FIG numbers — All Sizes.
F	=	FLANGES — Both FIG numbers — 2"- 4" only.
D	=	DRESSER — STANDARD AND LOCKING. FIG 425 only in sizes 3/4"-4", 3/4"-2" valves are machined for Dresser style 90 ends. 2 1/2"-4" are machined for Dresser style 38 ends. Dresser fittings are not included with the valve and must be ordered separately. As Shown on Page 5.
DI	=	DRESSER INSULATING — FIG 425 only in sizes 3/4"-4". Insulating end prevents electric flow along pipe. Dresser insulating valves have the end opposite the seat only machined for Dresser insulating fittings. The seat end of the valve is machined for Dresser standard fittings. Dresser fittings are not included with the valve and must be ordered separately. As Shown on Page 5.
V	=	VICTUALIC — FIG 425 only in sizes 3/4"-4". Victualic fittings are not included with the valve and must be ordered separately. To order fittings, specify requirements.

S,

Stem Seal

Give stem seal code as shown below:

1	=	Nitrile-Butadiene (BUNA) Use with RS49, RS50, and RS51 resilient plug seals.
2	=	Fluorinated Hydrocarbon (VITON) Use with RS54 resilient plug seal.
3	=	Isobutene Isoprene (HIGH TEMP) Use with RS55 resilient plug seals.

3,

Resilient Plug Seal

Give "RS" and number that follows. The service recommendations below are general classifications only. For specific recommendations, see KEY PORT Rubber Recommendations 60.00-2 or contact SMG VALVES.

RS49	=	Carboxylic-Nitrile-Butadiene (XNBR) (HYCAR) - A general service compound recommended for chemicals, natural gas, dry service and non-alkaline applications to 180° F
RS50	=	Chloroprene (CR) (NEOPRENE) - A general service compound recommended for alkaline applications to 180° F
RS51	=	Nitrile-Butadiene (NBR) (PETROLEUM HYCAR) - For manufactured gas and for petroleum applications at temperatures to 180° F. Can also be used for natural gas.
RS54	=	Fluorinated Hydrocarbon (FKM) (Fluoroelastomer) - For high temperature chemicals to 300° F.
RS55	=	Isobutene-Isoprene (CIIR) (HIGH TEMP) - For high temperature water to 250° F.

The service recommendations below are general classifications only. For specific recommendations, see KEY PORT VALVE Rubber Recommendations 60.00-2 or contact SMG VALVES.

Actuators & Accessories

All valves are furnished for lever actuation as standard. Levers are not mounted on the valve and must be ordered separately. To order, see FIG 483 on page 5. All valves can be furnished with on-off cylinder actuators.

Accessories are also shown on page 5.

FIG 487,

Dimensions

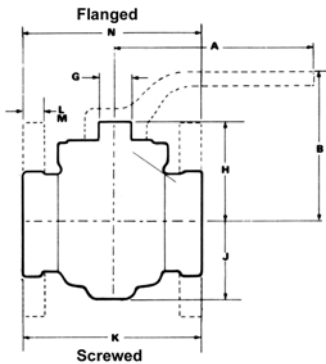

- L -- cast iron flanges
- F -- width of plug operating nut
- V -- dimension from valve centerline to top of optional drip cap
- Q -- length of dresser end valve body only (extra length for dresser accessories not included)
- R -- stab depth of pipe into dresser end valve body
- P -- length of victaulic end valve body only (extra length for victaulic accessories not included)

* weights are for FIG 425 only
 § on 3" and 4" valves, this plug square is rotated 45° from the open position as shown

VALVE SIZE inches (mm)	FIG. 425 DIMENSIONS (inches/mm)													VALVE WEIGHTS*		LEVER WEIGHTS (lbs/kg)
	A	B	F	G	H	J	K	L	N	P	Q	R	V	SCREWED (lbs/kg)	FLANGED (lbs/kg)	
½ (13)	4.00	3.50	.50	.81	2.03	1.25	3.25	.38	4.25	—	4.56	1.25	2.13	1.75	4.00	.75
	101.6	88.9	12.7	20.6	51.6	31.8	82.6	9.7	108.0		115.8	31.8	35.8	.79	1.81	.34
¾ (19)	4.00	3.63	.50	.81	2.16	1.44	3.75	.41	4.63	4.31	4.81	1.41	2.28	2.50	4.50	.75
	101.6	92.2	12.7	20.6	54.9	36.6	95.3	10.4	117.6	109.5	122.3	35.8	57.9	1.13	2.04	.34
1 (25)	5.00	4.00	.50	1.13	2.47	1.69	4.25	.44	5.00	4.63	5.25	1.63	2.81	3.75	6.75	1.00
	127.0	101.6	12.7	28.7	62.7	42.9	108.0	11.2	127.0	117.6	133.4	41.4	71.4	1.70	3.06	.45
1¼ (32)	5.00	4.25	.50	1.13	2.72	1.88	4.75	.50	5.50	5.00	6.00	1.88	3.00	5.25	8.25	1.00
	127.0	108.0	12.7	28.7	69.1	47.8	120.7	12.7	139.7	127.0	152.4	47.8	76.2	2.38	3.74	.45
1½ (38)	6.00	4.38	.50	1.13	2.81	2.00	5.00	.56	6.50	5.25	6.50	2.00	3.19	6.25	11.00	1.00
	152.4	111.3	12.7	28.7	71.4	50.8	127.0	14.2	165.1	133.4	165.1	50.8	81.0	2.83	4.99	.45
2 (50)	6.00	4.75	.50	1.13	3.16	2.31	5.50	.63	7.00	6.63	7.38	2.25	3.47	9.00	15.25	1.00
	152.4	120.7	12.7	28.7	80.3	58.7	139.7	16.0	177.8	168.4	187.5	57.2	88.1	4.05	6.92	.45
2½ (64)	8.00	5.50	.50	1.63	3.94	2.88	6.88	.69	7.50	6.50	8.75	2.50	4.19	15.00	24.00	2.00
	203.2	139.7	12.7	41.4	100.1	73.2	174.8	17.5	190.5	165.1	222.3	63.5	106.4	6.80	10.89	.90
3 (75)	10.00	5.75	1.44	1.44	4.66	3.25	7.50	.75	8.00	7.13	9.50	2.50	4.69	22.00	32.00	2.25
	254.0	146.1	36.6	36.6	118.4	82.3	190.5	19.1	203.2	181.1	241.3	63.5	119.1	9.98	14.51	1.02
4 (100)	12.00	6.88	1.59	1.59	5.94	4.25	9.25	.94	9.00	8.81	10.00	2.50	6.00	47.00	61.00	4.00
	304.8	174.8	40.4	40.4	150.9	108.0	235.0	23.9	228.6	223.8	254.0	63.5	152.4	21.32	27.67	1.81

**For Sales, Service & Parts Please Contact Your Local Factory
 Authorized Representative**

SMG VALVES a Unit of Southern Mfg. Group, Inc.

KEY PORT SERIES 400 ECCENTRIC VALVES

7693 Manchester Hwy.
 Morrison, TN 37357
 Phone: (931) 668-5377
 Fax: (931) 668-5378
 Email: smginc@blomand.net
 Web: www.keyportvalve.com or
 www.smg-global.com

SMG VALVES reserves the right to incorporate our latest design and material changes without notice or obligation. Design features, materials of construction and dimensional data, as described in this bulletin, are provided for your information only and should not be relied upon unless confirmed in writing by SMG VALVES. Certified drawings are available upon request.